

SANDSTONE BUSINESS PARK

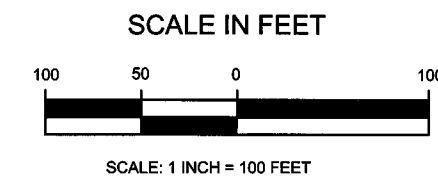

LEGEND

- DENOTES 3/4 INCH X 18 INCH IRON PIPE MONUMENT SET IN ACCORDANCE WITH MS 505.021, SUBD. 10, MARKED BY LICENSE NO. 52146
- DENOTES A 1/2 INCH IRON PIPE MONUMENT FOUND AND MARKED BY LICENSE NO. IF KNOWN
- ⊙ DENOTES PINE COUNTY SECTION CORNER MONUMENT

BEARING BASIS

FOR THE PURPOSE OF THIS PLAT THE SOUTH LINE OF THE SW 1/4 OF SEC. 16-T.42-R.20 IS ASSUMED TO BEAR S89°36'20"E

DRAINAGE AND UTILITY EASEMENTS ARE SHOWN THUS:

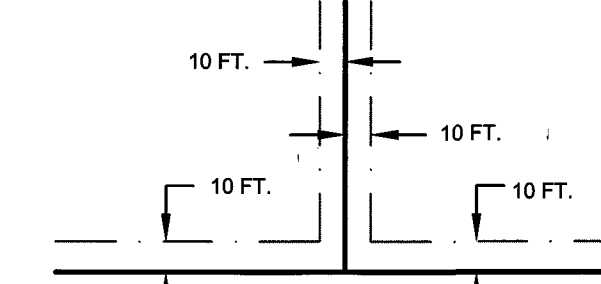

BEING 10 FEET IN WIDTH ALONG SIDE LOT LINES, PUBLIC WAYS AND REAR LOT LINES. NOT TO SCALE.

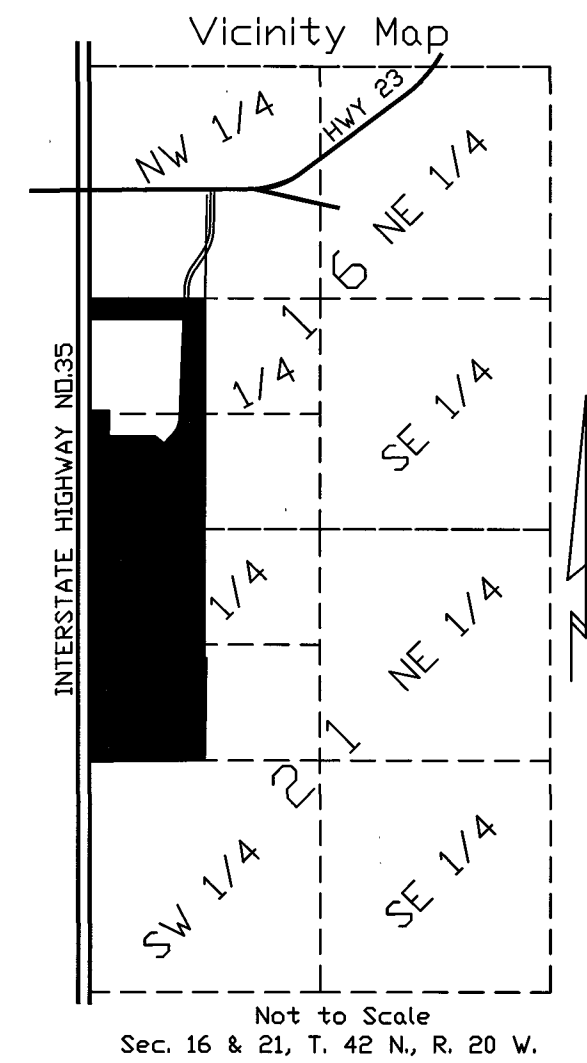

KNOW ALL PERSONS BY THESE PRESENTS: That the Economic Development Authority of Sandstone, a public body corporate and politic in the State of Minnesota, owner of the following described property:

The Southwest Quarter of the Northwest Quarter and the Northwest Quarter of the Northwest Quarter of Section 21, and the Southwest Quarter of the Southwest Quarter and the Northwest Quarter of the Southwest Quarter of Section 16, all in Township 42, Range 20, Pine County, Minnesota, less the right of way of the Great Northern Railway Company.

EXCEPTING THEREFROM;

That part of the Northwest Quarter of the Southwest Quarter of Section 16, Township 42 North, Range 20 West, Pine County, Minnesota, described as follows:

Commencing at the southwest corner of the Northwest Quarter of the Southwest Quarter of said Section 16; thence North 01 degree 09 seconds 04 minutes East, assumed bearing, along the west line of said Northwest Quarter of the Southwest Quarter a distance of 64.01 feet to the point of beginning of the land to be described; thence South 89 degrees 48 minutes 12 seconds East along a line parallel with the south line of said Northwest Quarter of Southwest Quarter a distance of 1027.12 feet to a point on the westerly right-of-way line of Lundorff Drive; thence North 02 degrees 13 minutes 54 seconds East along said westerly right-of-way line a distance of 1017.11 feet; thence South 89 degrees 59 minutes 46 seconds West along a line parallel with the north line of the Northwest Quarter of the Southwest Quarter a distance of 1046.37 feet to the west line of the Northwest Quarter of the Southwest Quarter; thence South 01 degree 09 minutes 04 seconds West along said west line a distance of 1012.95 feet to the point of beginning.

ALSO EXCEPTING THEREFROM;

That part of the Northwest Quarter of the Southwest Quarter and the Southwest Quarter of the Southwest Quarter of Section 16, Township 42 North, Range 20 West, Pine County, Minnesota, described as follows:

Commencing at the northwest corner of the Southwest Quarter of the Southwest Quarter of said Section 16; thence North 01 degree 09 minutes 04 seconds East, assumed bearing, along the west line of said Section 16 a distance of 64.01 feet; thence South 89 degrees 48 minutes 12 seconds East along a line parallel with the north line of said Southwest Quarter of Southwest Quarter a distance of 244.82 feet to the point of beginning of land to be described; thence continuing South 89 degrees 48 minutes 12 seconds East a distance of 782.30 feet to a point on the westerly right-of-way line of Lundorff Drive; thence South 02 degrees 13 minutes 54 seconds West along said westerly right-of-way line a distance of 82.63 feet; thence southerly continuing along said right-of-way line a distance of 184.64 feet along a tangential curve concave to the West having a radius of 260.00 feet and a central angle of 40 degrees 41 minutes 19 seconds; thence South 42 degrees 55 minutes 13 seconds West along said westerly right-of-way line a distance of 147.27 feet; thence North 52 degrees 05 minutes 54 seconds West a distance of 128.10 feet; thence North 89 degree 48 minutes 12 seconds West a distance of 513.93 feet; thence North 01 degree 09 minutes 04 seconds East a distance of 279.62 feet to the point of beginning.

Has caused the same to be surveyed and platted as SANDSTONE BUSINESS PARK, and does hereby donate and dedicate to the public for public use the public ways and drainage and utility easements as created by this plat.

In witness whereof said Economic Development Authority of Sandstone, a public body corporate and politic in the State of Minnesota, has caused these presents to be signed by its proper officers this 31st day of October, 2016.

Phillip Kester, President. Jessica Seibert, Executive Director.

STATE OF Minnesota
COUNTY OF Pine

The foregoing instrument was acknowledged before me this 31st day of October, 2016, by Phillip Kester, President and Jessica Seibert, Executive Director.

Olave H. Tyson
Notary Public, Pine County, Minnesota
My Commission Expires January 31, 2017

I, Greg B. Lundquist, Professional Land Surveyor, do hereby certify that this plat was prepared by me or under my direct supervision; that I am a duly Licensed Land Surveyor in the State of Minnesota, and that this plat is a correct representation of the boundary survey; that all mathematical data and labels are correctly designated on the plat; that all monuments depicted on this plat have been, or will be correctly set within one year; that all water boundaries and wet lands, as defined in Minnesota Statutes 505.01, Subd. 3, as of the date of this certificate are shown and labeled on this plat; and all public ways are shown and labeled on the plat.

Dated this 27th day of October, 2016.

Greg Lundquist
Greg B. Lundquist, Licensed Land Surveyor
Minnesota License No. 52146

STATE OF Minnesota
COUNTY OF Washington

The foregoing instrument was acknowledged before me this 27th day of October, 2016, by Greg B. Lundquist, a Licensed Land Surveyor.

Dana Marie Koehn
Notary Public, Washington County, Minnesota
My Commission Expires January 31, 2021

CITY OF SANDSTONE, PINE COUNTY, MINNESOTA

Approved by the City Council of the City of Sandstone, Pine County, Minnesota, this 19th day of October, 2016 and is in compliance with the provisions of the Minnesota Statutes Section 505.03, Subdivision 2.

By: [Signature]
Mayor

By: Jessica Seibert
Clerk

PINE COUNTY AUDITOR

No delinquent taxes and transfer entered this 15th day of November, 2016.

[Signature]
County Auditor

PINE COUNTY TREASURER

I hereby certify that the taxes for the year 2016 on the property described herein are paid this 15th day of November, 2016.

[Signature]
County Treasurer

PINE COUNTY RECORDER

DOCUMENT NO. 530147

I hereby certify that this instrument was filed in the Office of the County Recorder for record on this 15th day of November, 2016, at 1:25 o'clock P.M., and was duly recorded in Pine County Records.

[Signature]
County Recorder

SANDSTONE BUSINESS PARK



UNPLATTED

UNPLATTED

UNPLATTED

UNPLATTED

UNPLATTED

UNPLATTED

UNPLATTED

UNPLATTED

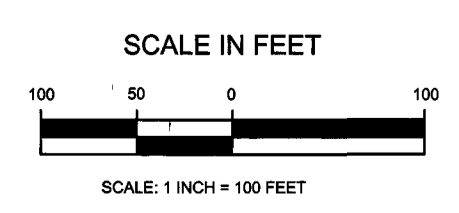

LEGEND

- DENOTES 3/4 INCH X 18 INCH IRON PIPE MONUMENT SET IN ACCORDANCE WITH MS 505.021, SUBD. 10, MARKED BY LICENSE NO. 52146
- DENOTES A 1/2 INCH IRON PIPE MONUMENT FOUND AND MARKED BY LICENSE NO. IF KNOWN
- ⊙ DENOTES PINE COUNTY SECTION CORNER MONUMENT

DRAINAGE AND UTILITY EASEMENTS ARE SHOWN THUS:

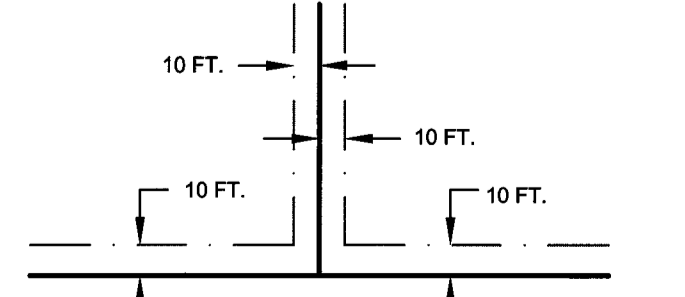

BEARING BASIS

FOR THE PURPOSE OF THIS PLAT THE SOUTH LINE OF THE SW 1/4 OF SEC. 16-T-42-R-20 IS ASSUMED TO BEAR S89°36'20"E

PHONE: 651.490.2000
3535 VADNAIS CENTER DR.
ST. PAUL, MN 55110-5196
www.sehinc.com

SANDSTONE BUSINESS PARK

DETAIL A

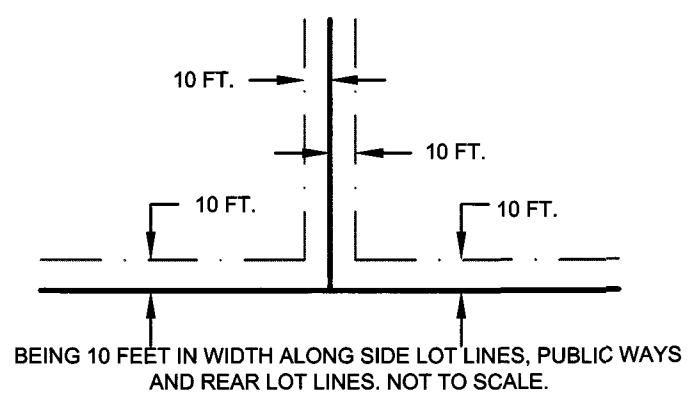
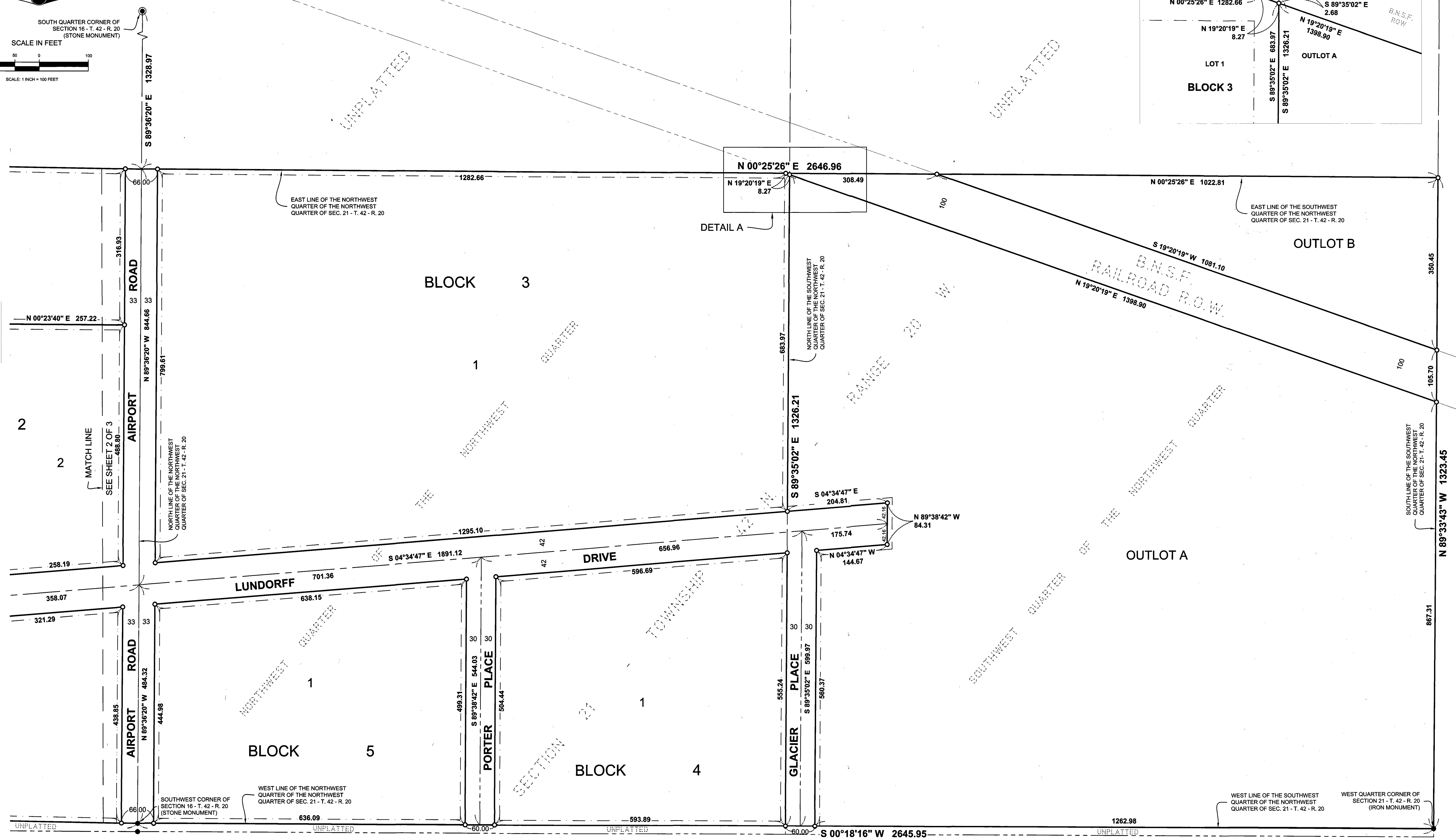
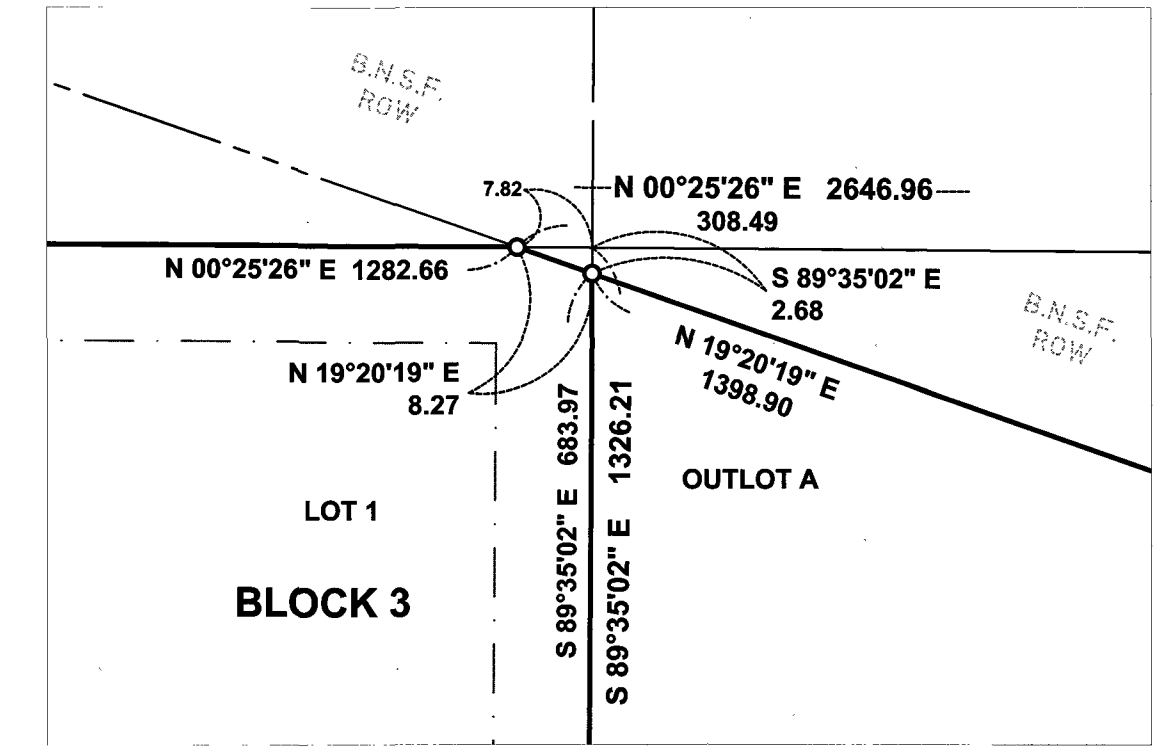
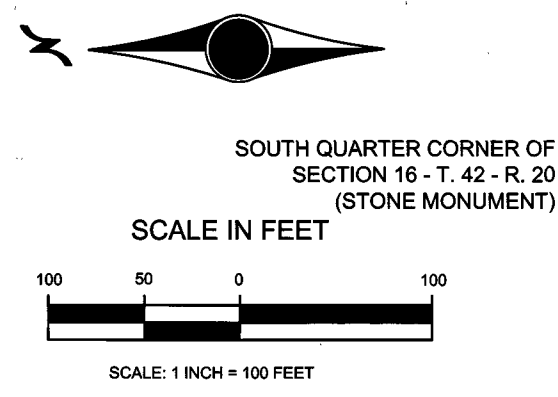

- LEGEND**
- DENOTES 3/4 INCH X 18 INCH IRON PIPE MONUMENT SET IN ACCORDANCE WITH MS 505.021, SUBD. 10, MARKED BY LICENSE NO. 52146
 - DENOTES A 1/2 INCH IRON PIPE MONUMENT FOUND AND MARKED BY LICENSE NO. IF KNOWN
 - ⊙ DENOTES PINE COUNTY SECTION CORNER MONUMENT

BEARING BASIS

FOR THE PURPOSE OF THIS PLAT THE SOUTH LINE OF THE SW 1/4 OF SEC. 16-T.42-R.20 IS ASSUMED TO BEAR S89°36'20"E